



Excellence is our standard.

# The Hurricane Frame

Engineered for the worst conditions



## Assembly Instructions

Standard Version



Excellence is our standard.

# Standard Hurricane Frame

## Engineered for the worst conditions

- *Never take down panels for a hurricane again.*
- *The Standard design is engineered to withstand winds up to 120 mph.*
- *The rear vinyl blocks wind and light and can serve as a self-promo space.*
- *Extensions install easily using the Formetco Clip-It Cut-Out System.*
- *Available in standard and custom sizes.*
- *Our frame enhances your display with a finished look.*

### Table Of Contents

HF Frame Components	3 - 4
HF Frame Assembly	5 - 9
HF Frame Installation	10
HF Mast & Frame Spacing	11 - 20
HF 10' 6" x 36"	11
HF 10' x 30'	12
HF 10' x 40'	13
HF 12' x 24'	14
HF 12' x 30'	15
HF 12' x 40'	16
HF 12' x 44'	17
HF 14' x 43'	18
HF 14' x 48'	19
HF 20' x 60'	20
HF Inside Vinyl Installation	21
HF Flexible Vinyl Installation	22
HF Clip-It Cut-Out System	23 - 26

# HF Frame Components

HF Frame Bracket Fixed - Mounted to top and bottom of the interior HF Masts and to the HF Side Masts to support the HF Frame.

HF Backing Plate - Mounted inside Masts behind the HF Frame Mounting Brackets.

HF Frame Bracket Fixed and HF Backing Plate mounted using two 1/2" x 1 1/2" Flange Bolts and Flange Nuts.

HF Mast - The HF Masts come cut to length for your face size.

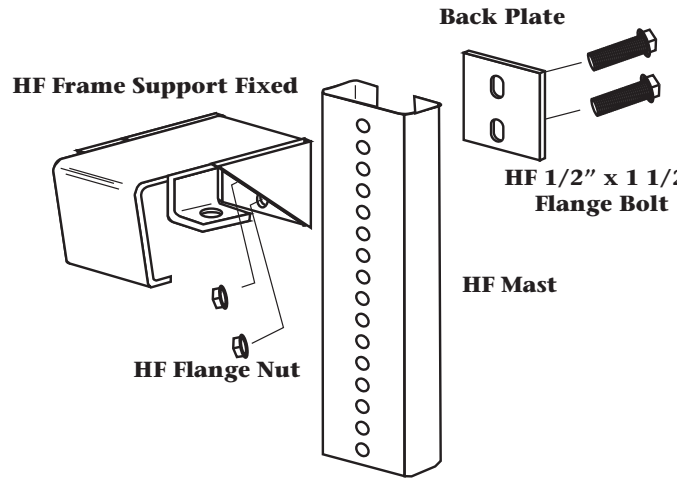

<i>Face Size</i>	<i>HF Mast Length</i>
10'	9' 10" (118")
10' 6"	10' 4" (124")
12'	11' 10" (142")
14'	13' 10" (166")
20'	2 - 119" Mast And Mast Splice Plate

HF Double Sided Hanger Plate - Mounted on Masts at stringer locations to easily hang on angle iron stringers. Attach to Mast with two 1/2" x 1 1/2" Carriage Bolts and Flange Nuts.

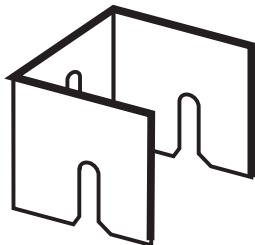
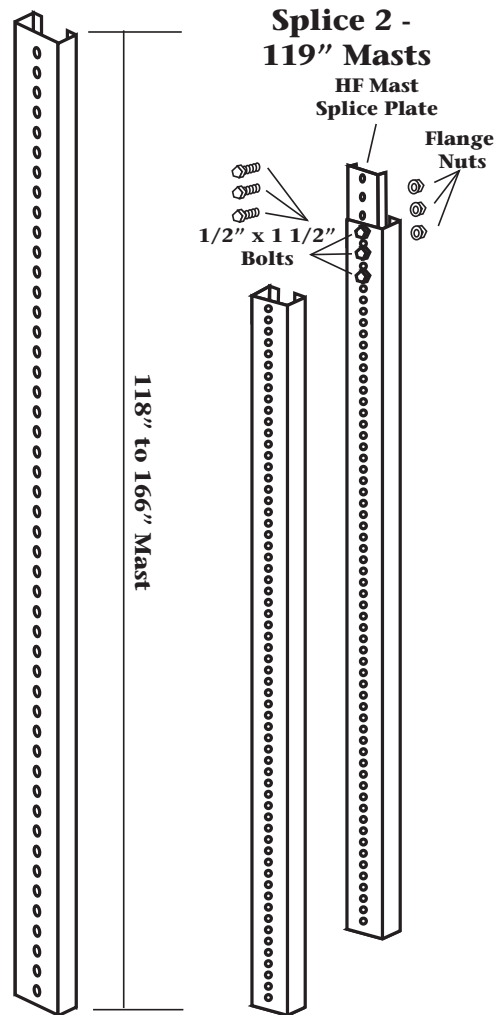

**HF Double Sided  
Hanger Plate**

# HF Frame Components

HF Frame - The HF Frame Top and Bottom comes in 138" lengths and is pre-punched for fast and easy installation. Depending on the face size you may get a pre-cut length shorter than 138". Example: a 10' 6" x 36' face would have 4 - 138" lengths and 2 - 132' lengths whereas a 14' x 48' would have 8 - 138" lengths.

The HF Side Frame would be pre-cut to length. Splice plates included where needed.

HF Frame Corner is made to fit perfectly with the Top, Bottom and Side Frames. HF Corners are 12" x 12".

HF Frame Splice Plate - The HF Frame Splice Plates come in two sizes. The 12" Splice is to attach the HF Corners to the Top, Bottom and Side Frames. The 24" Splice is to attach the Top, Bottom or Side Frames end to end.

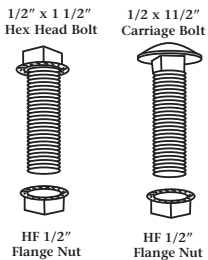
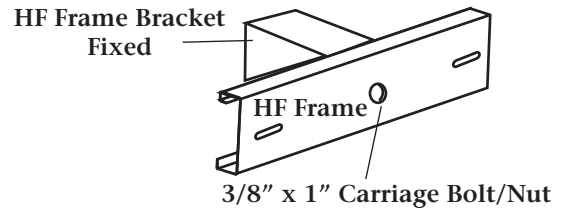
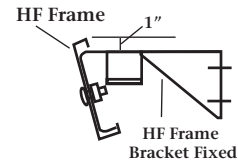

HF Bolts & Nuts - The HF 1/2" x 1 1/2" Flange Bolt is used to attach the HF Frame Bracket Fixed and HF Backing Plate to the Mast. The 1/2" x 1 1/2" Carriage Bolts is used to attached the HF Double Hanger Plates to the Mast.

The 3/8" x 1" Carriage Bolt is used to attach the HF Frame to the HF Frame Bracket Fixed and to attach the HF Frame Splice Plates on the front of the HF Frame and on the outside edges. The 3/8" x 1 1/2" Hex Bolt is used to attach the HF Frame to the HF Frame Splice Plate on the inside edge. The HF Flange Nut is used on all bolts.

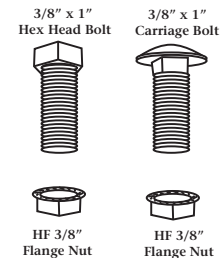

HF Flat Washer - Used between the HF Frame Bracket Fixed and the Mast when the HF Double Hanger Plate has to be mounted where it is located near the top or bottom of the mast.

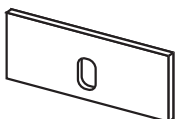

HF Flat Washer

The HF Inside Vinyl Hook - Attach the inside vinyl in the HF Frame.

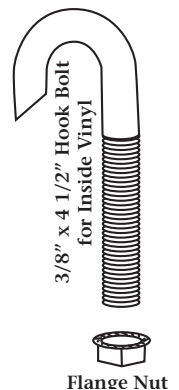

# HF Frame Assembly

## Step 1

Mark Your stringer spacing for each HF Mast. (See page 5)

Attach the HF Double Hanger Plates to each HF Mast with the 1/2" x 1 1/2" Carriage Bolts and Flange Nuts.

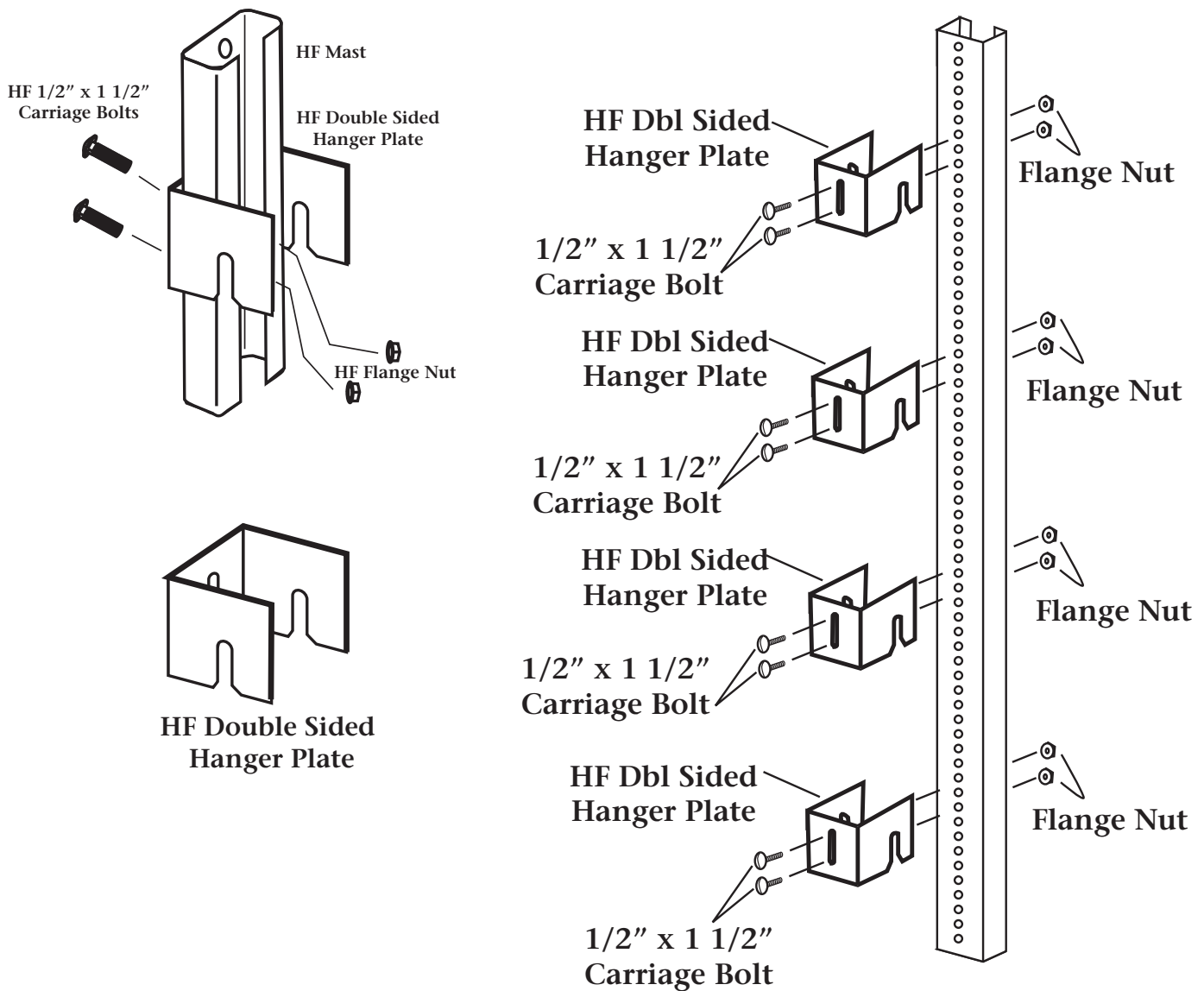

# HF Frame Assembly

## Optional Hanger Spacings for 14' Masts

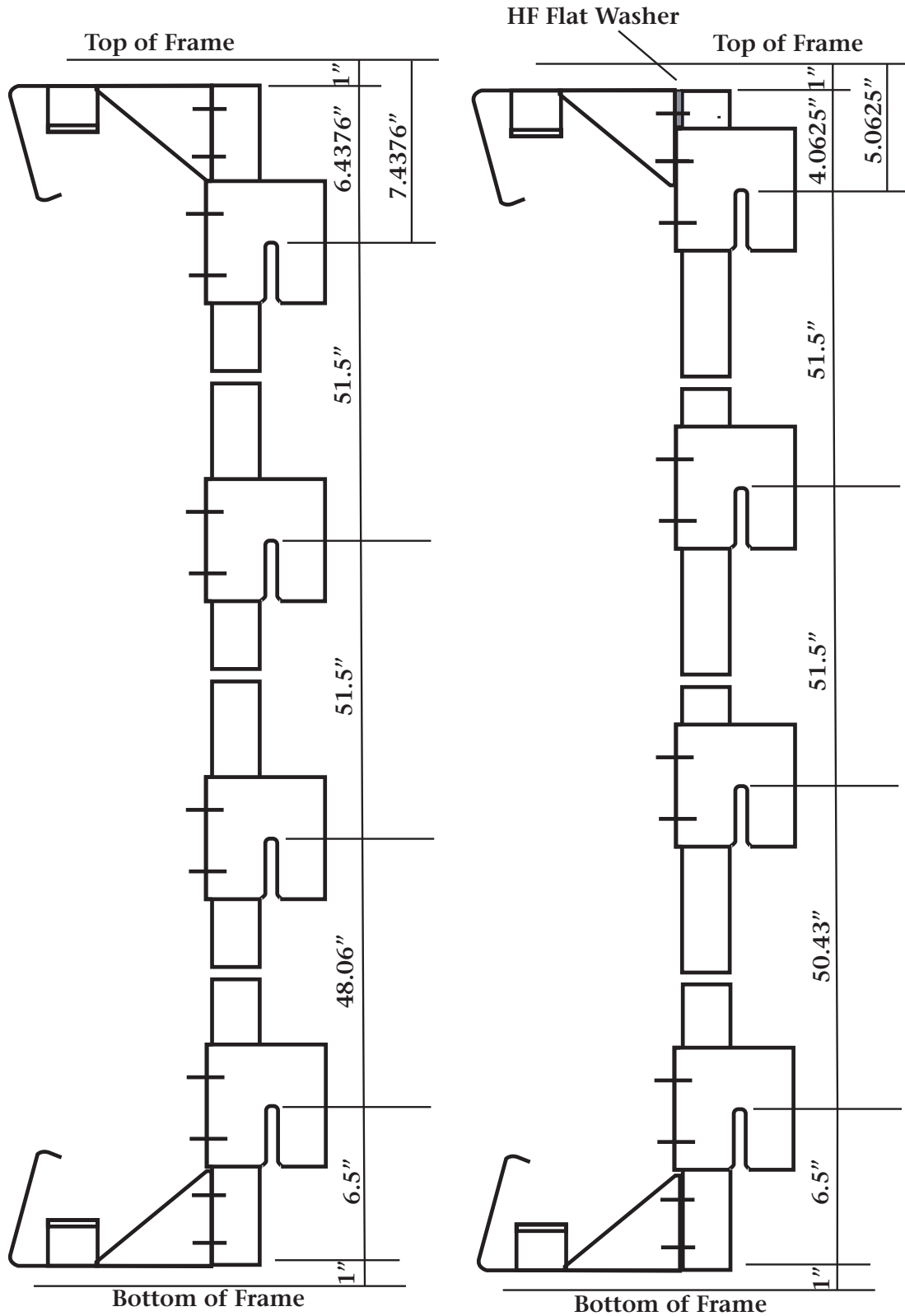

# HF Frame Assembly

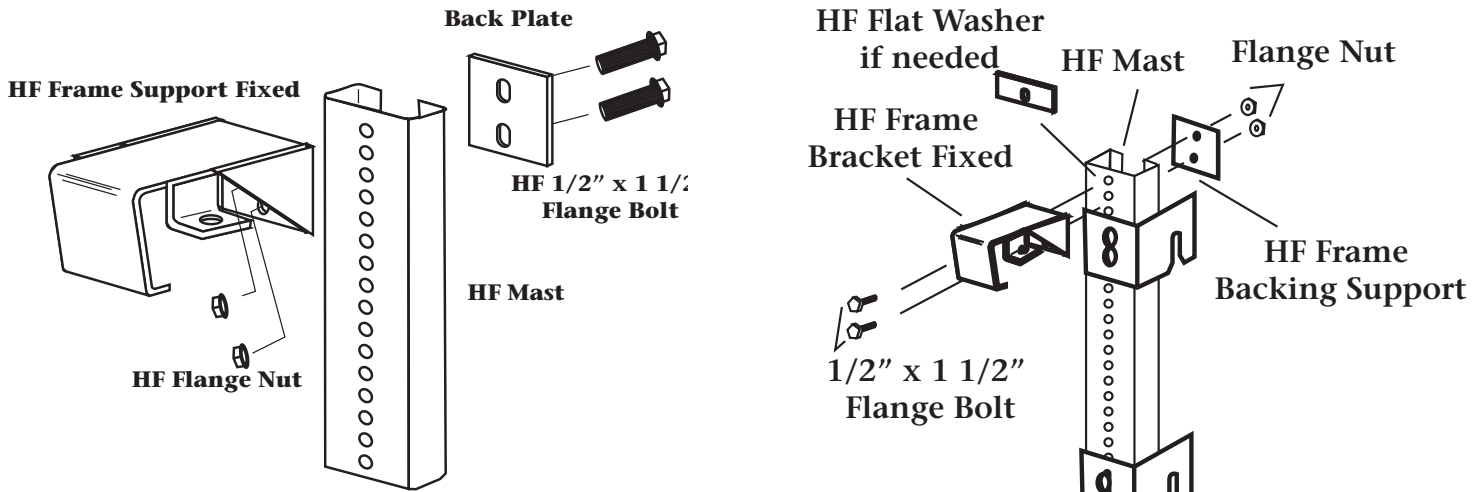

## Step 2

Attach the HF Frame Bracket Fixed with a HF Backing Support at the top and bottom of each interior HF Mast using 1/2" x 1 1/2" Flange Bolts and Flange Nuts.

Note: The HF Double Hanger Plate may be required to be attach under the HF Frame Bracket Fixed because of stringer spacing. In this case use the HF Flat Washer to fill in behind the Hf Frame Bracket.

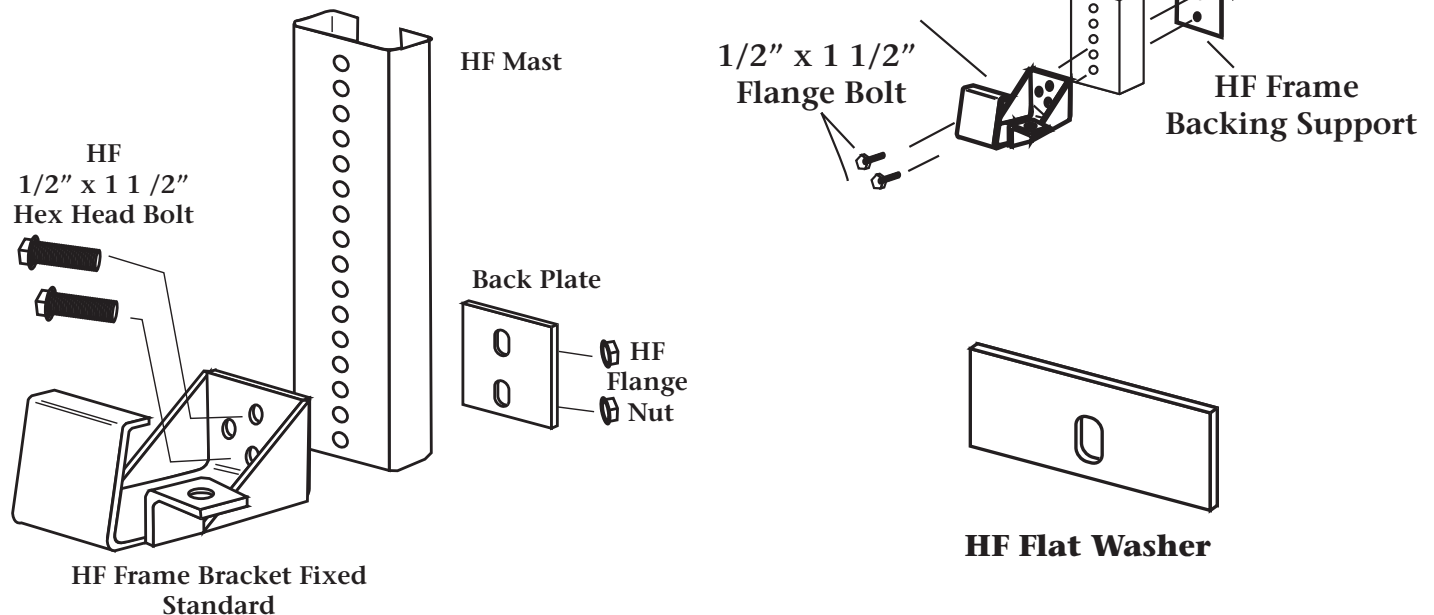

# HF Frame Assembly

## Step 3

Attach the HF Frame Bracket Fixed and HF Backing Plates to the HF Side masts using HF Flange Bolts and Flange Nuts. One HF Frame Bracket for each stringer.

*Note: The side HF Frames and the HF Frame Corners with Splice can be attached to the side frames at this time.*

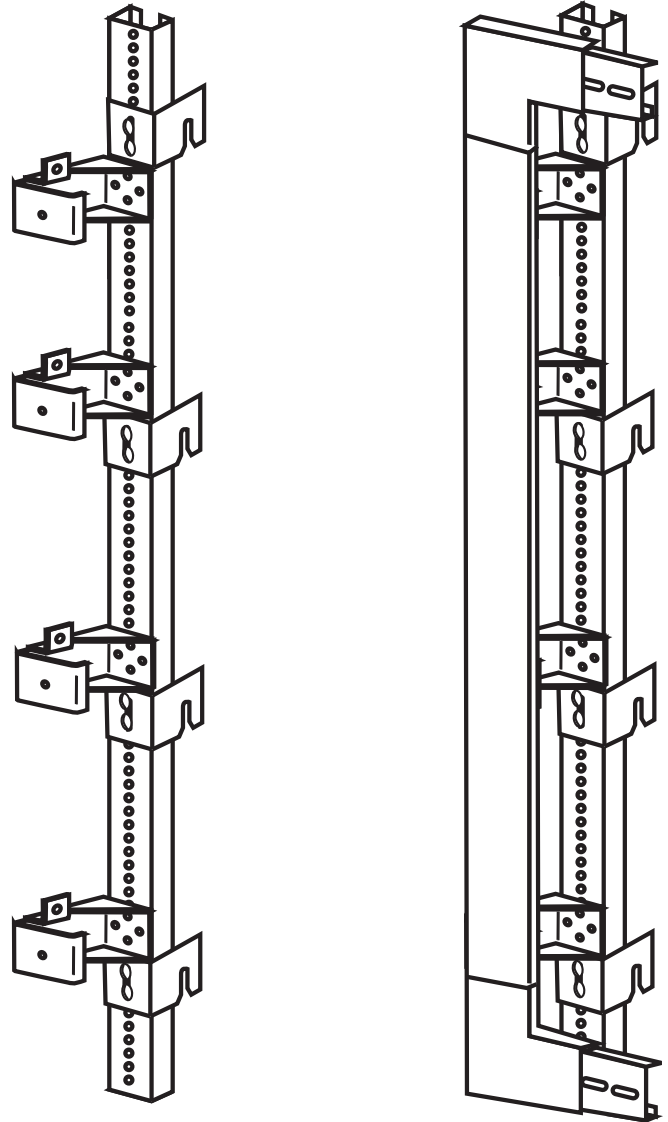
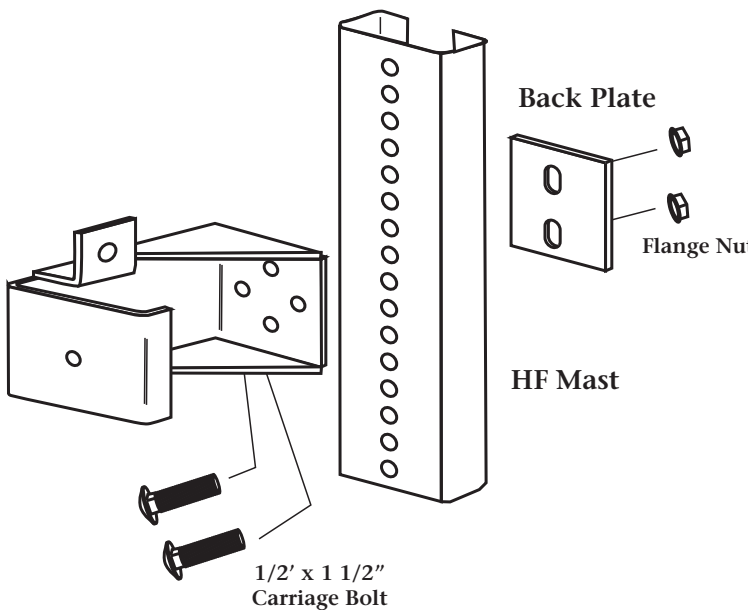

*Note: Top and/or Bottom Side HF Frame Support Bracket on 4 stringer structures may need to be mounted below the top HF Double Hanger Plate and above the bottom HF Double Hanger Plate so as to not interfere with the Frame Corner.*

# HF Frame Assembly



Top and Bottom Frame  
138"



Side Frame Cut to Length  
Except on 20' sides

## Step 4

Attach the HF Frame to the HF Frame Bracket Fixed with the 3/8" x 1 1/2" Carriage Bolts.

Attach the 24" HF Frame Splice Plates to the HF Frame and the 12" HF Splice Plates to the HF Corners with the 3/8" Carriage Bolts on the front and outside edge. The Carriage Bolt allows the vinyl to slide easily over the HF Frame. Use the 3/8" Hex Head Bolt on the inside edge of the HF Frame. Use the Flange Nuts on all bolts.

*Note: You can completely assemble the HF Hurricane Frame on the ground and lift in place using a Spreader Bar. Do not lift without a spreader bar.*

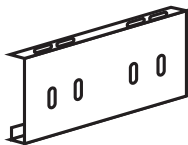
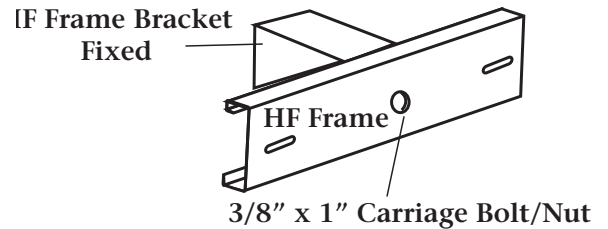
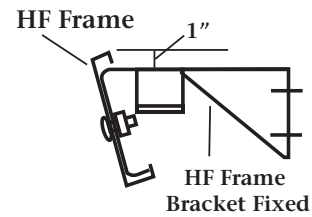

HF Corner Splice Plate  
12"

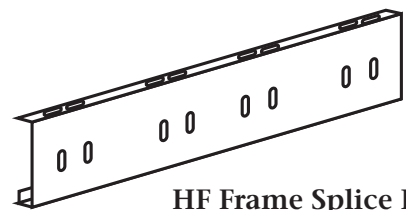

HF Frame Splice Plate  
24"

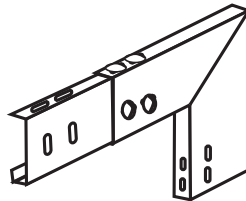

HF Frame Corner  
with 12" Splice

3/8" x 1" Carriage Bolt/Nut  
(Front and Outside Edge)

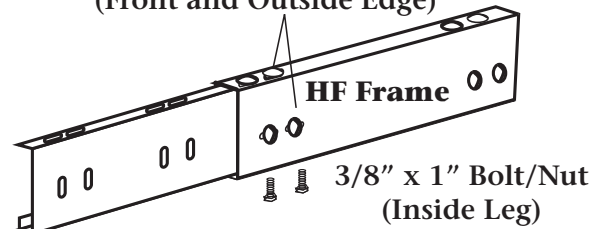

HF Frame with 24" Splice



Excellence is our standard.

# HF Frame Installation

The Formetco HF Hurricane Frames can be assembled on the ground at the site and installed on the structure with a crane and spreader bar.

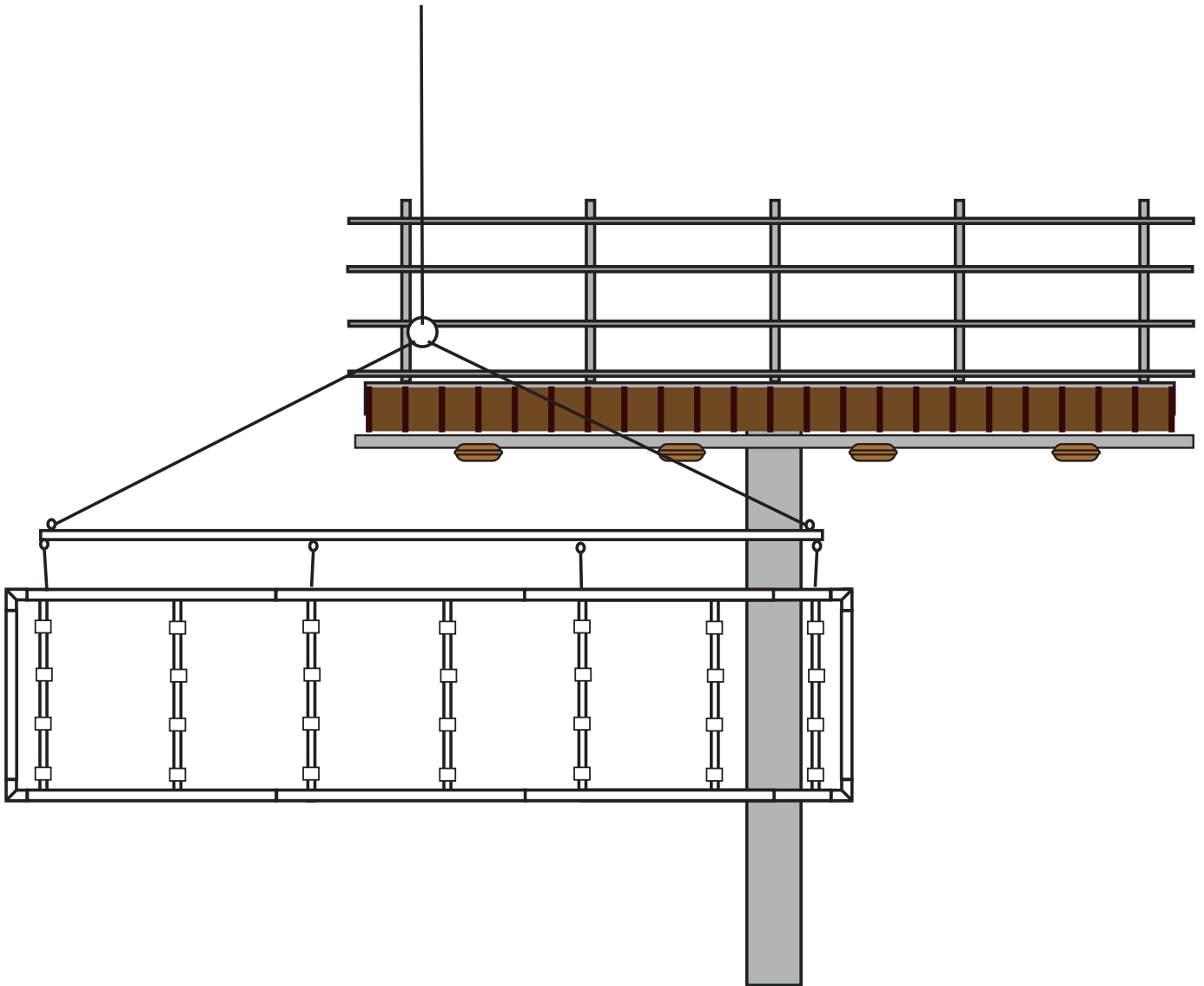

# Mast Spacing 10' 6" x 36' HF Frame

## HF Mast Spacing 10' 6" x 36'

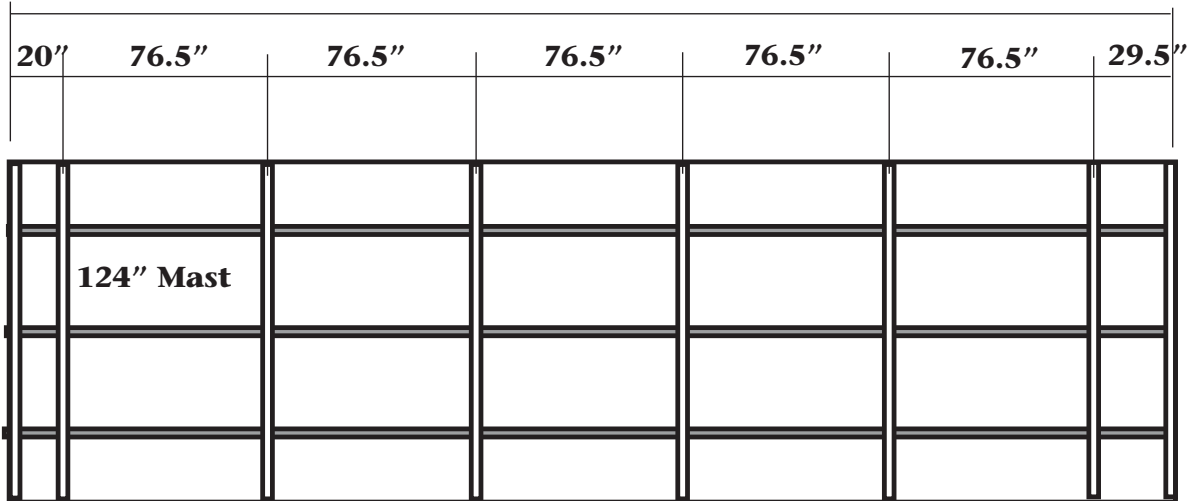

## HF Frame Spacing 10' 6" x 36'

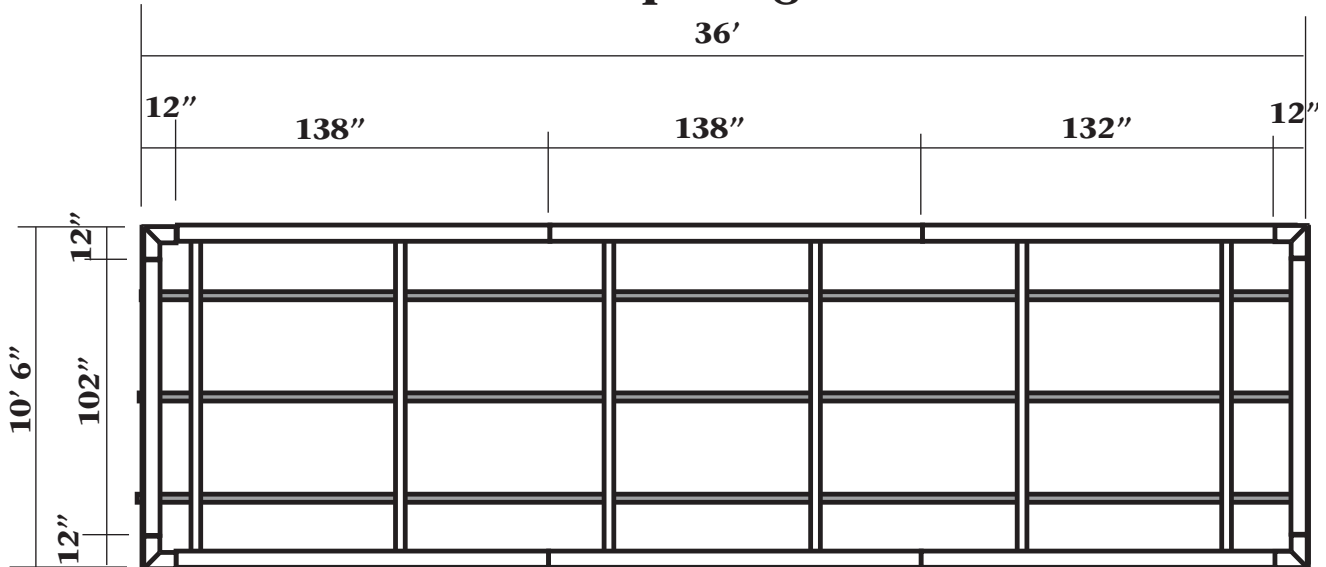

# Mast Spacing 10' x 30' HF Frame

## HF Mast Spacing 10' x 30'

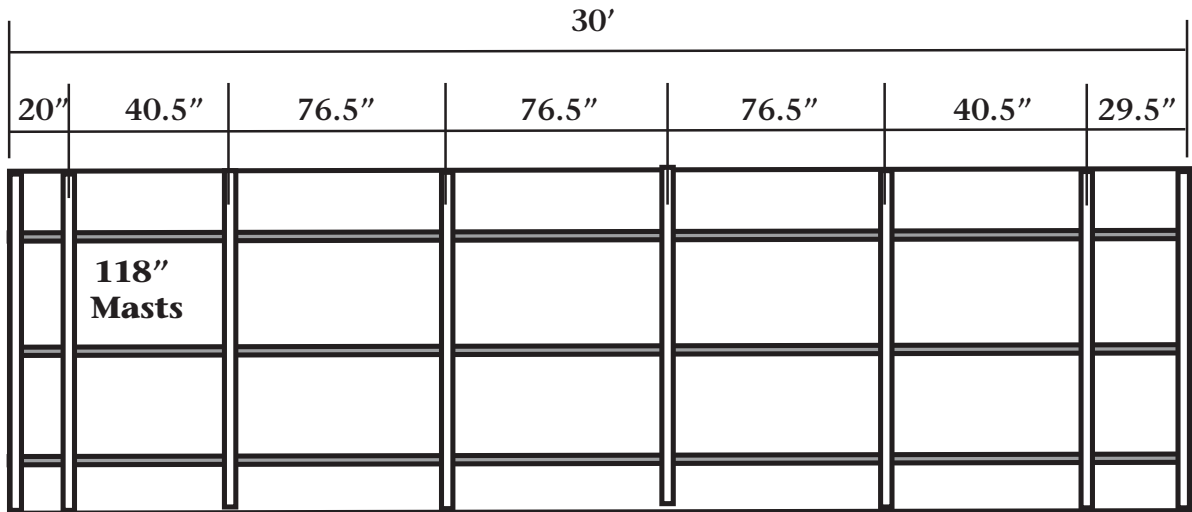

## HF Frame Spacing 10' x 30'

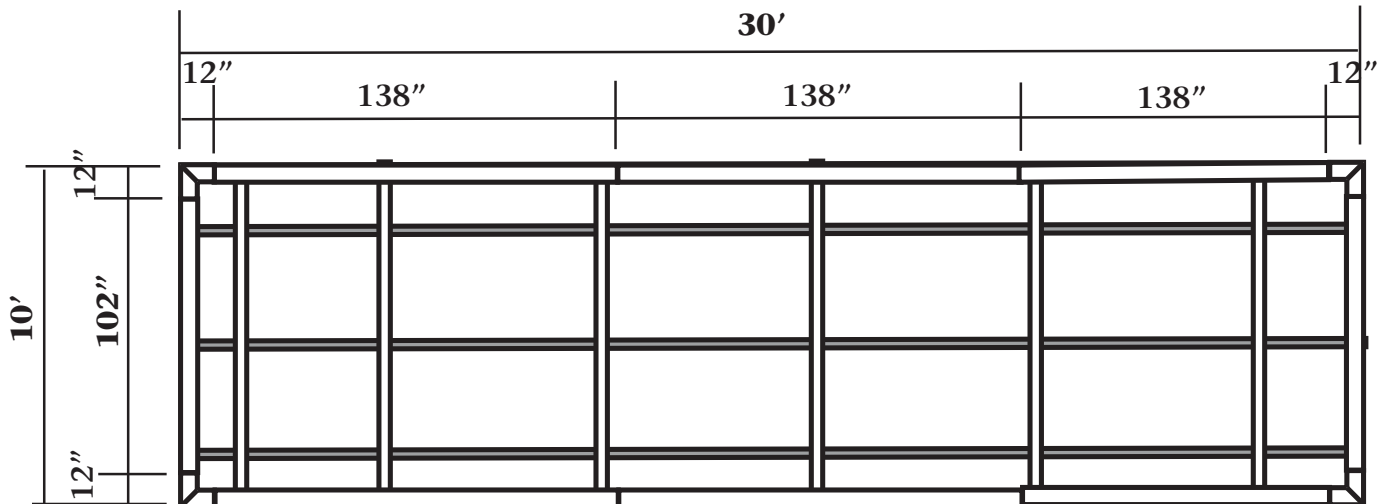

# Mast Spacing 10' x 40' HF Frame

**HF mast Spacing 10' x 40'**

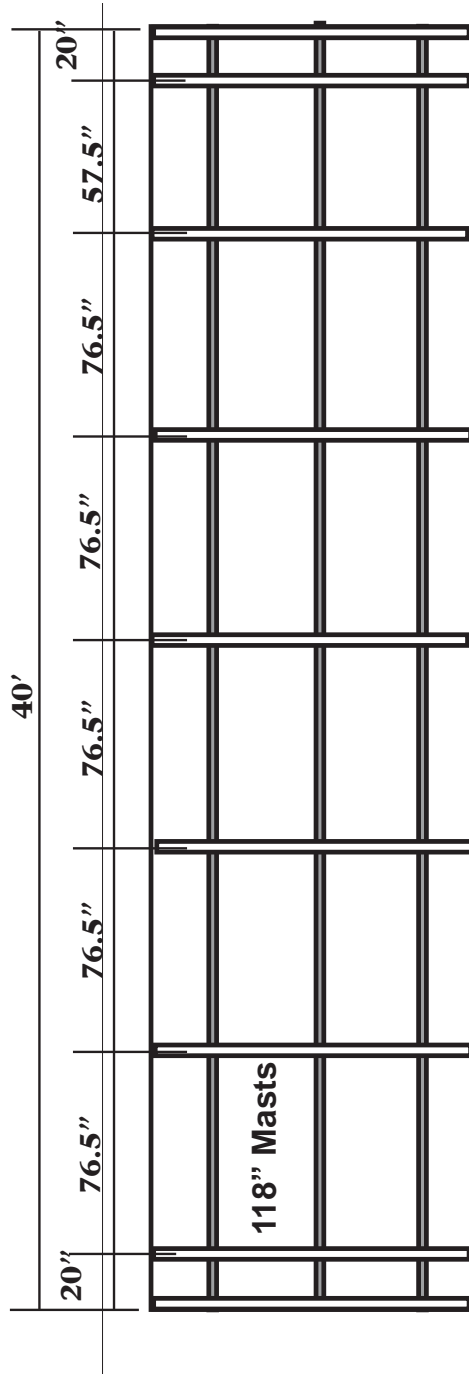

**HF Frame Spacing 10' x 40'**

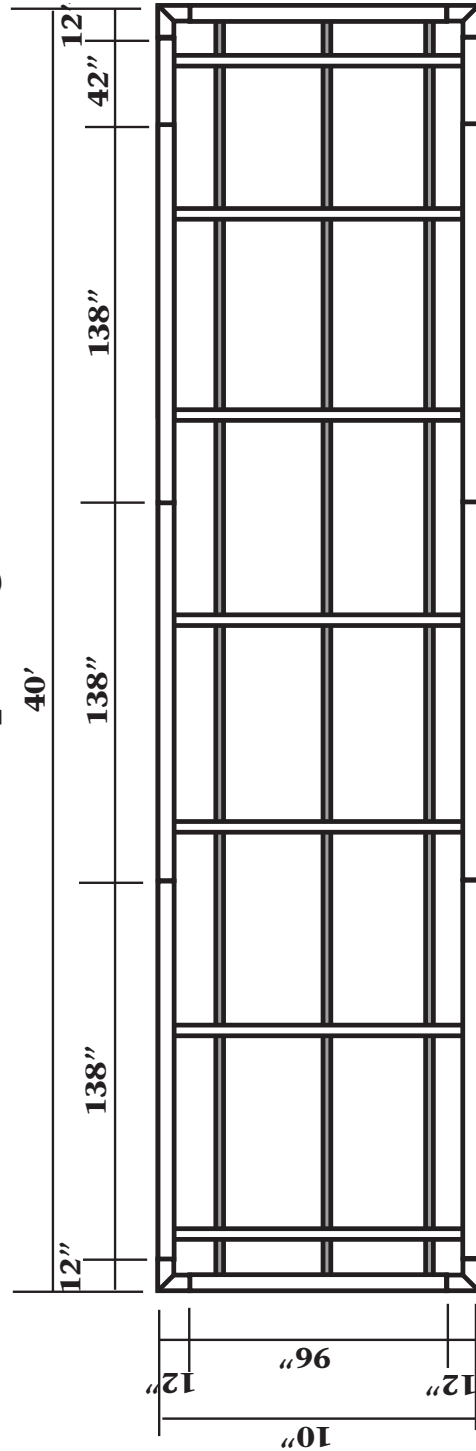

# Mast Spacing 12' x 24' HF Frame

## 12' x 24' HF Mast Spacing

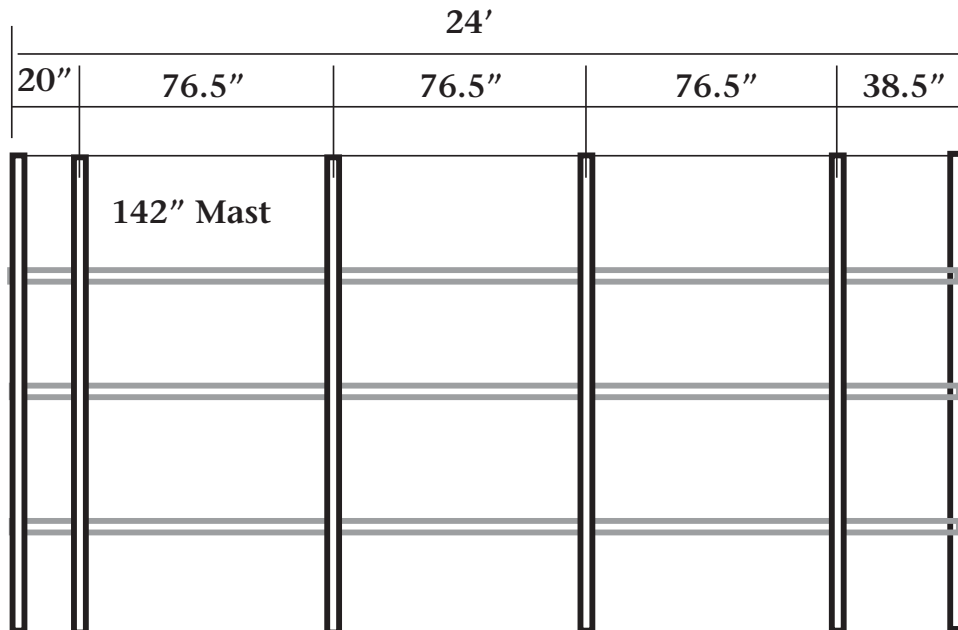

## 12' x 24' HF Frame Spacing

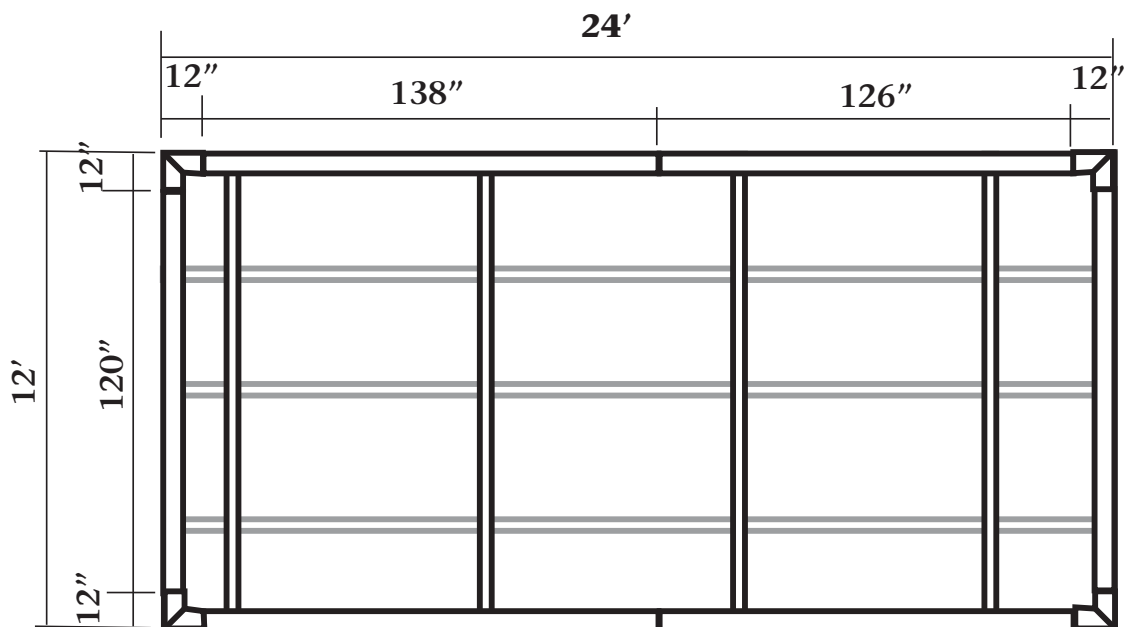

# Mast Spacing 12' x 30' HF Frame

**HF Mast Spacing 12' x 30'**

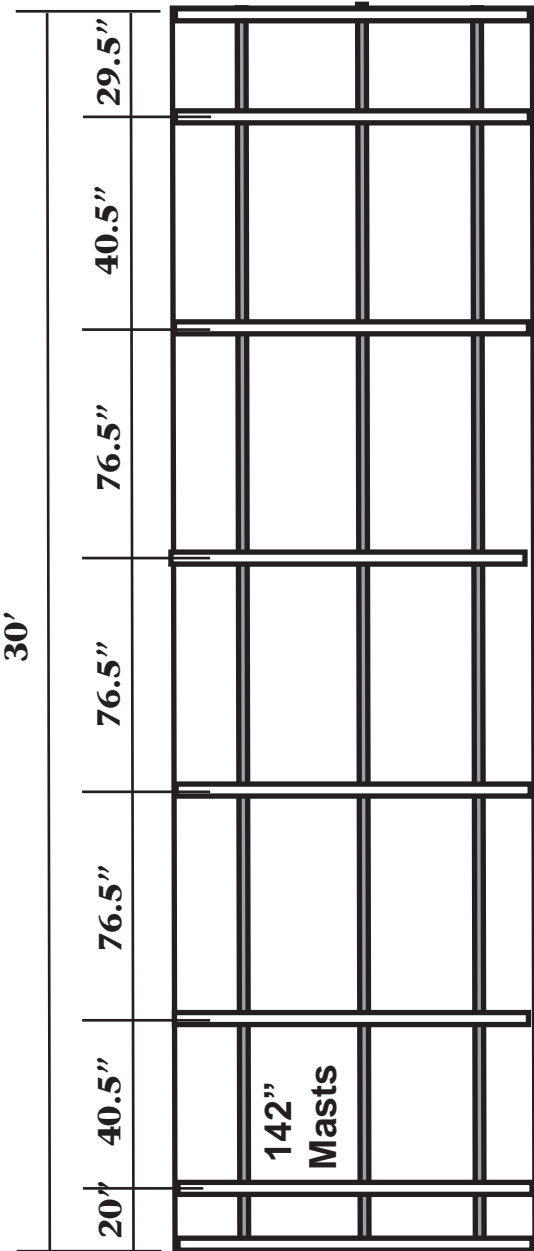

**HF Frame Spacing 12' x 30'**

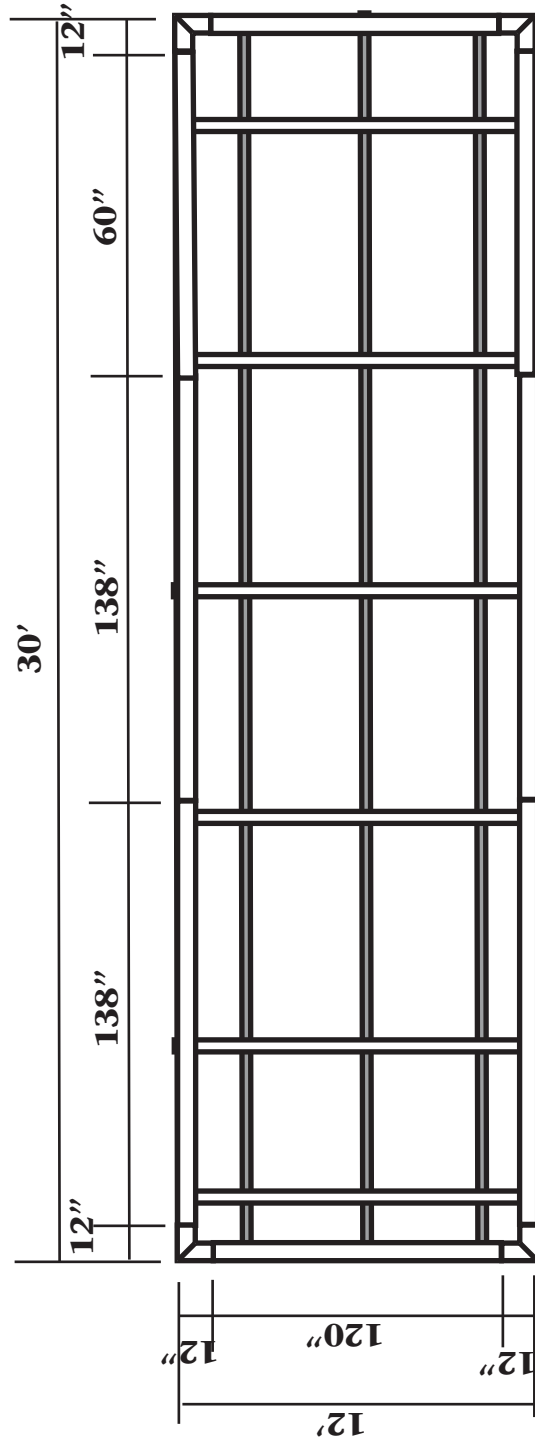

# Mast Spacing 12' x 40' HF Frame

**HF Mast Spacing 12' x 40'**

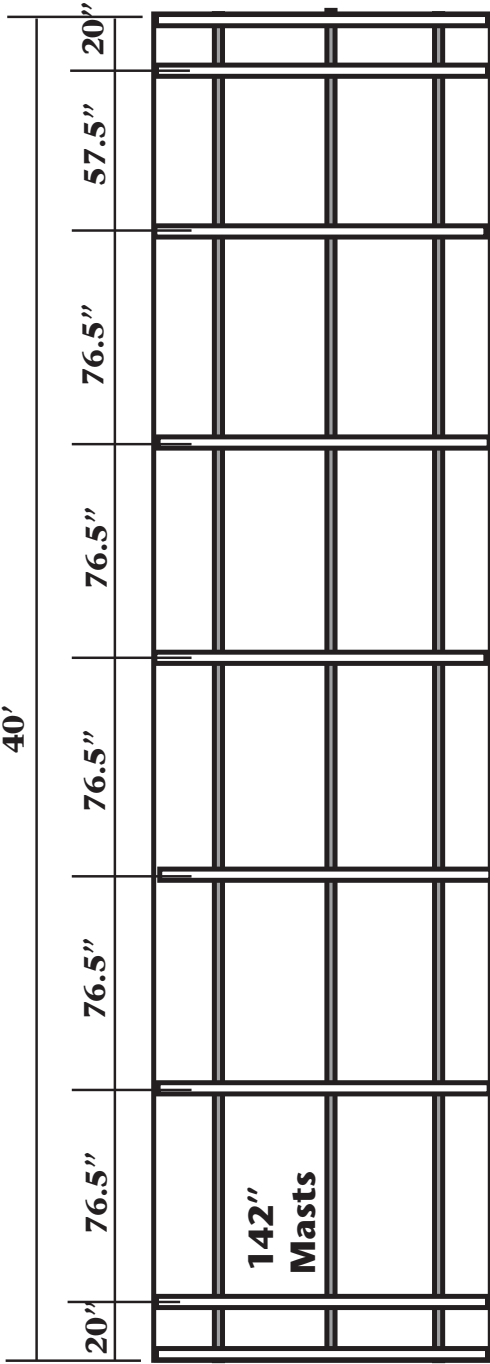

**HF Frame Spacing 12' x 40'**

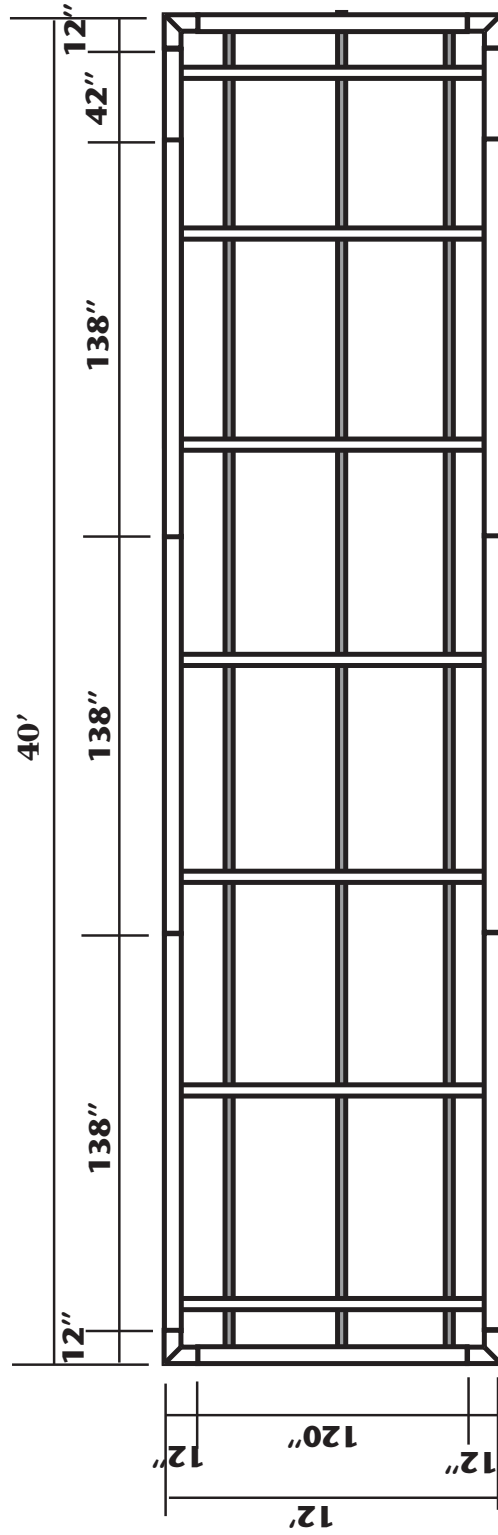

# Mast Spacing 12' x 44' HF Frame

## HF Mast Spacing 12' x 44'

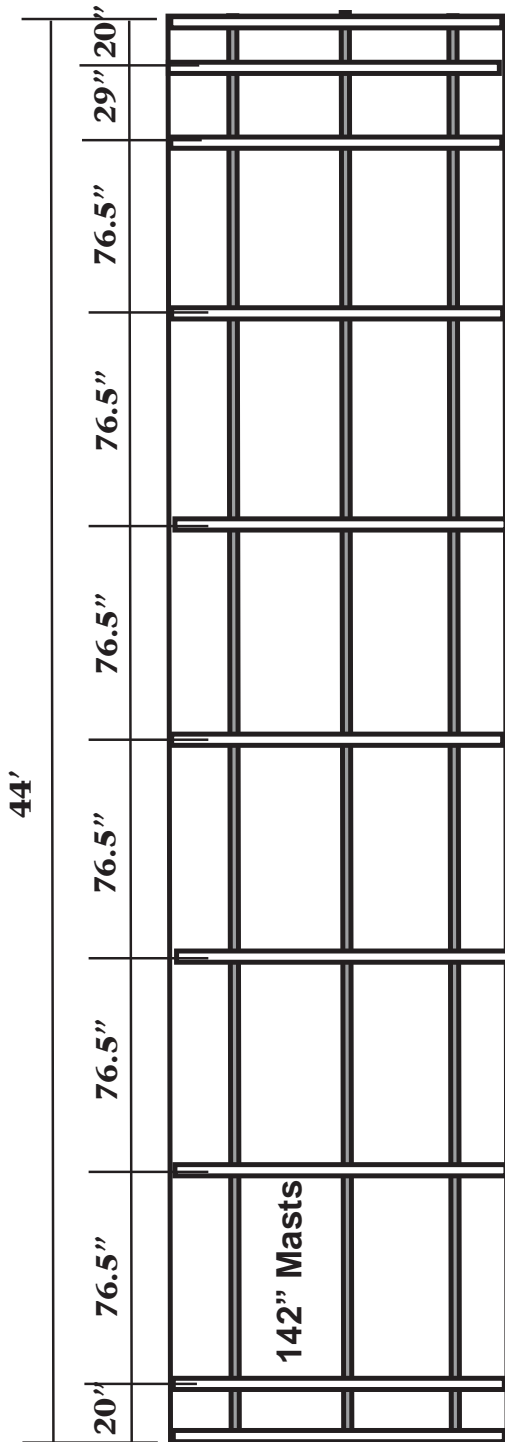

## HF Frame Spacing 12' x 44'

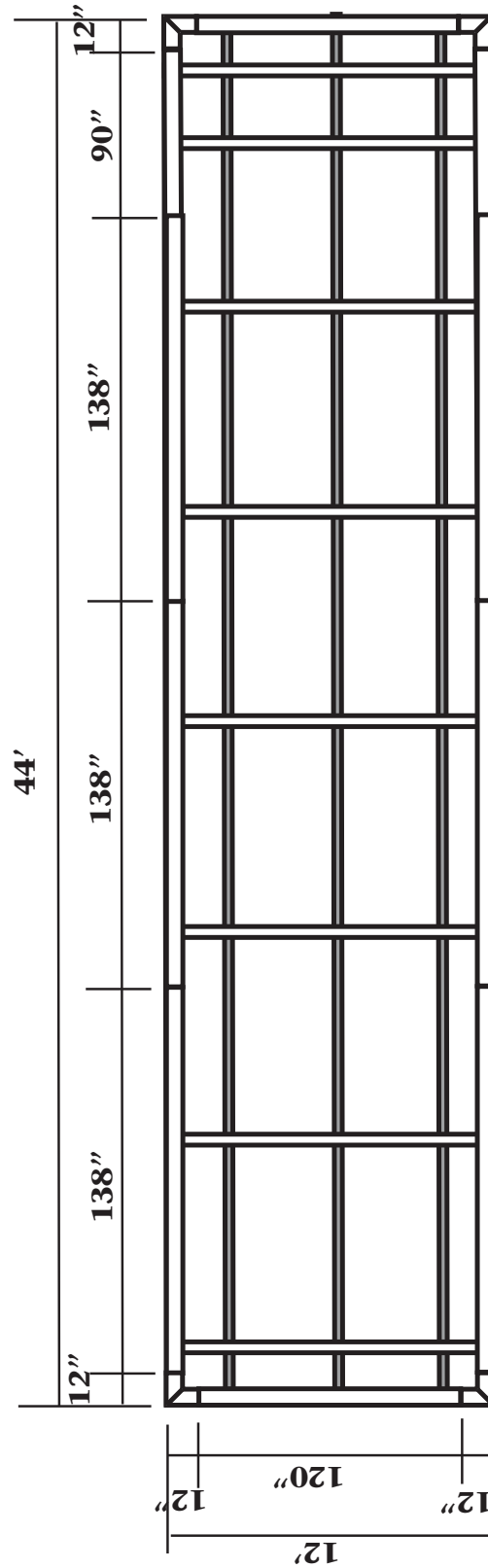



# Mast Spacing 14' x 48' HF Frame

**HF Mast Spacing 14' x 48'**

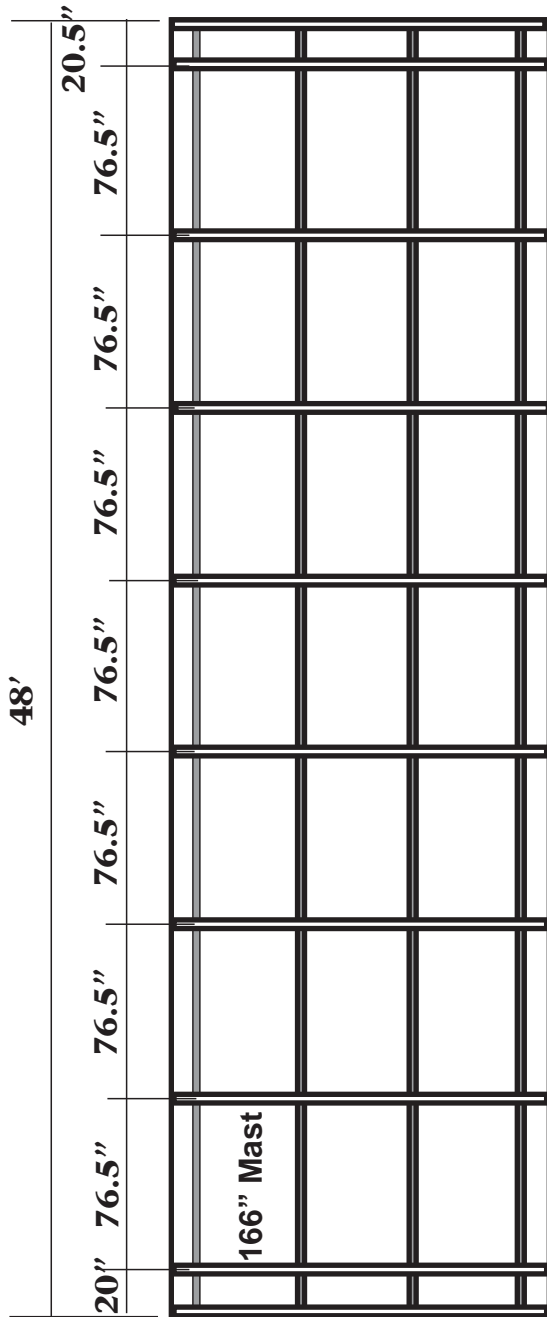

**HF Frame Spacing 14' x 48'**

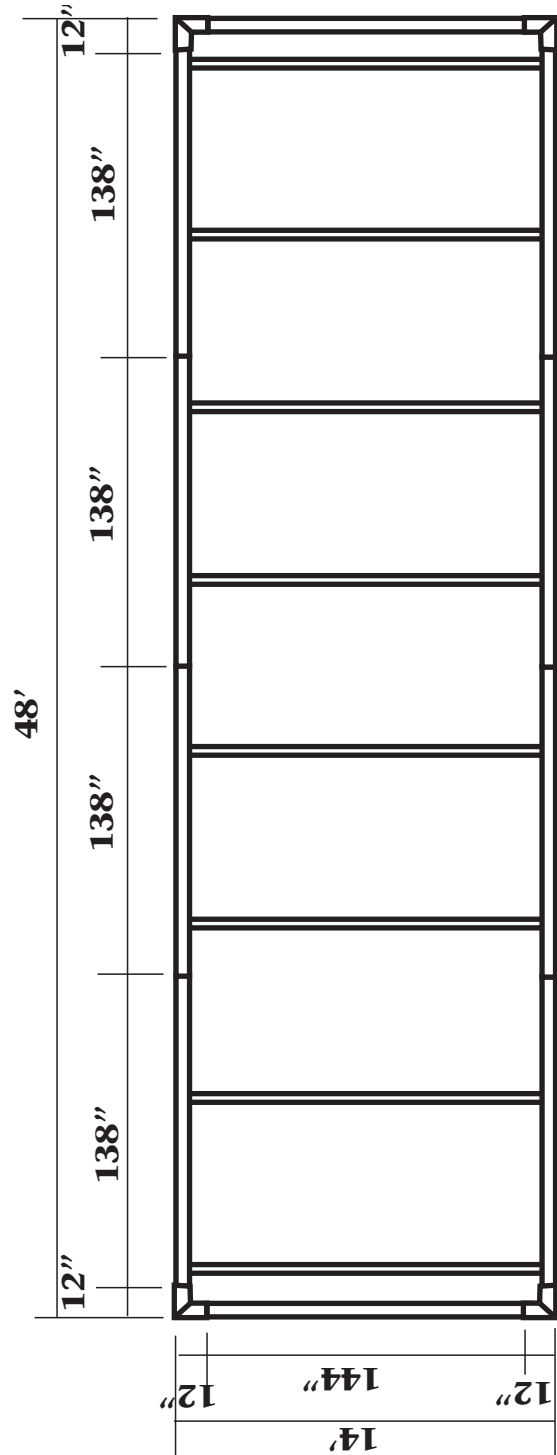



# Inside Vinyl Installation

Attach one 3/8" x 4 1/2" Hook bolt in one of the tabs on the HF Frame Bracket Fixed. NOTE: Make sure the Hook Bolt on the top bracket is directly above the one in the bottom bracket. The same applies to the side brackets. Leave hook bolt loose in bracket.

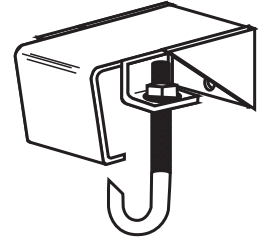

3/8" x 4 1/2" Hook Bolt  
for Inside Vinyl



Flange Nut

Place Gripper Bars in vinyl, regular or mesh, pockets. Slide Gripper bars onto the Hook Bolts. Tighten the Hook Bolts to stretch the vinyl.

See Chart below for Inside Vinyl Dimensions.

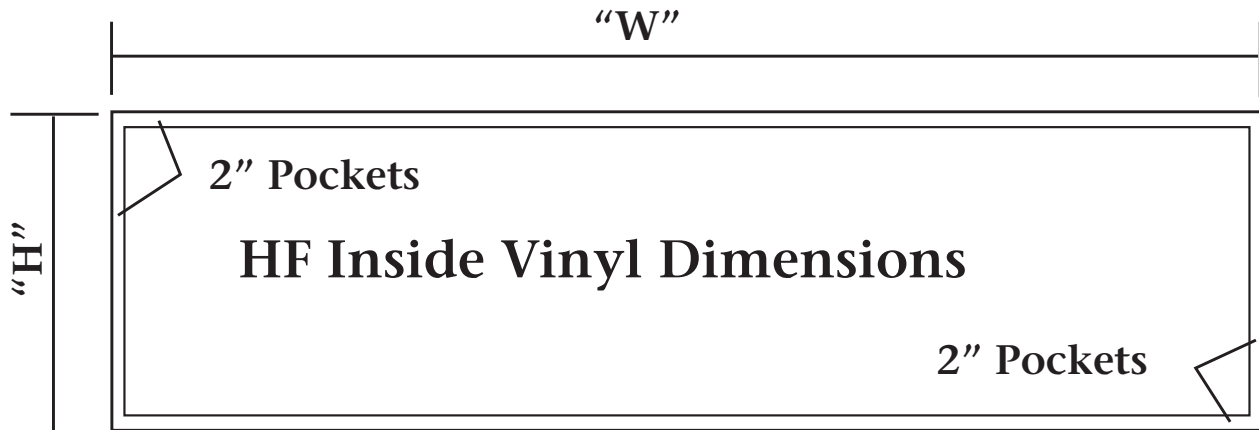
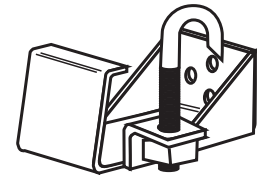

Frame Size	Inside Vinyl Size	
	"H"	"W"
10' x 40'	111" (9' 3")	471" (39' 3")
10' 6" x 36'	117" (9' 9")	423" (35' 3")
12' x 24'	135" (11' 3")	279" (23' 3")
14' x 48'	159" (13' 3")	567" (47' 3")
20' x 60'	231" (19' 3")	711" (59' 3")

# HF Flexible Vinyl Installation

Install flexible vinyls on HF Hurricane Frames using Gripper bars and ratchets.

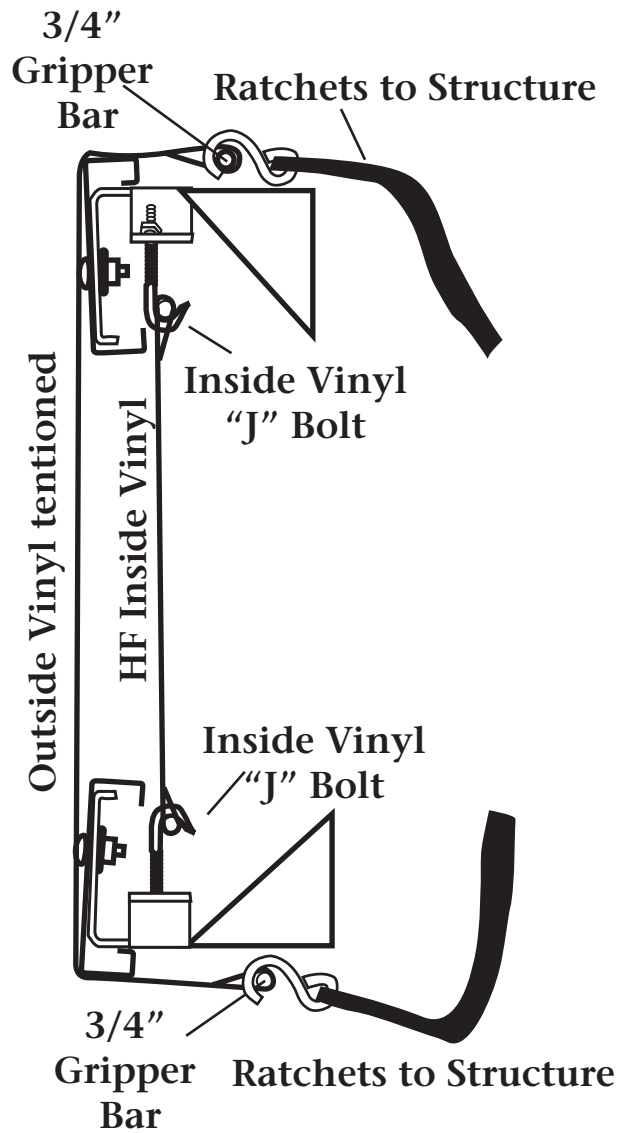
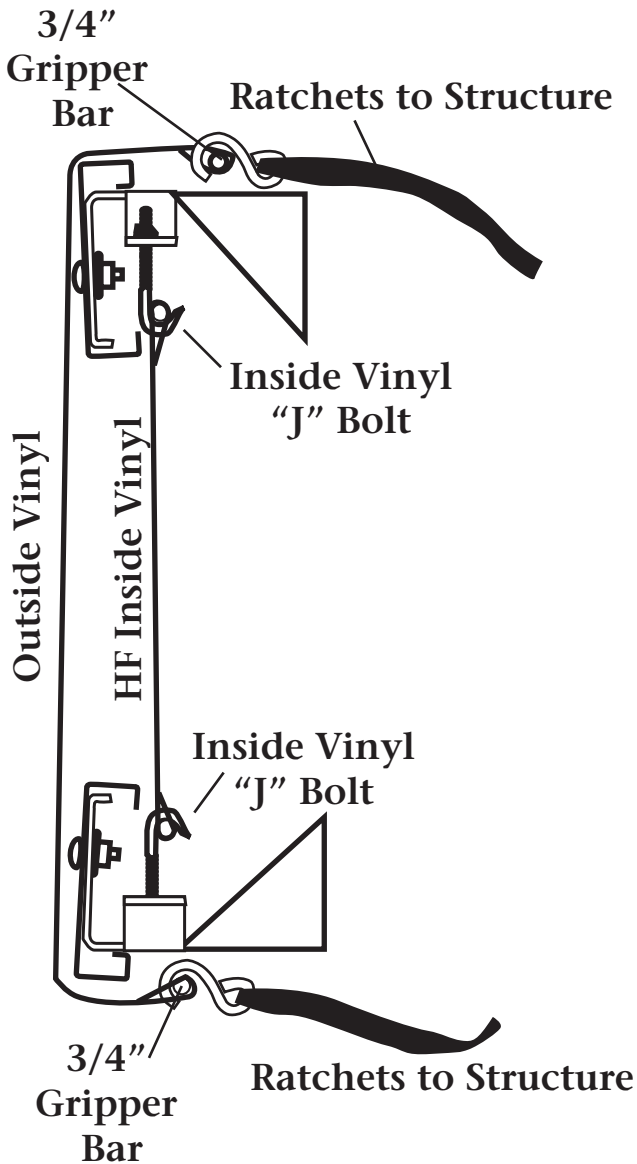

# HF Clip-It Cut-Out System

1. Assemble the 8' extension using either 1/2" plywood or 1/2" Dura-Ply with a 2x backing material.

*Note: When ordering the Universal Retainers specify which plywood you are using 1/2" plywood or 1/2" Dura-Ply. There is a difference in the thickness of each. The Universal Retainer upright fin is installed between the extension face material and the 2x material*

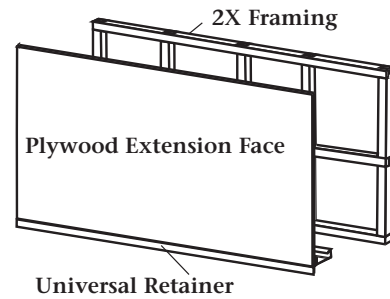

2. Drill 3/8" holes through the plywood, Universal Retainer and the 2x every 9" to 10" across and 1" up from the bottom of the plywood.

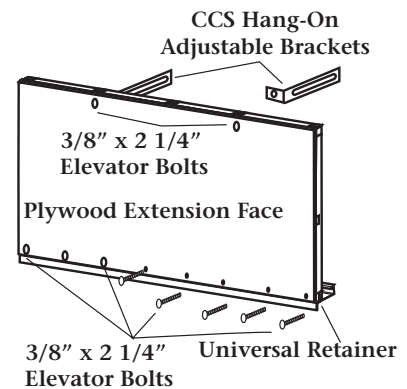

3. Insert a 3/8" x 3" Elevator Bolt through each hole from the front of the extension. Insert a 3/8" washer and a Flange Nut on each bolt and tighten until the flat head of the bolt is flush with the plywood face.

4. Drill two 3/8" holes at or near the top of the extension, about 18" from each side to attach the Cut-Out mast.

5. Inset a 3/8" x 3" Elevator Bolt through each hole. Use a 3/8" Washer and a Flange Nut to tighten bolt until the flat head is flush with the plywood face.

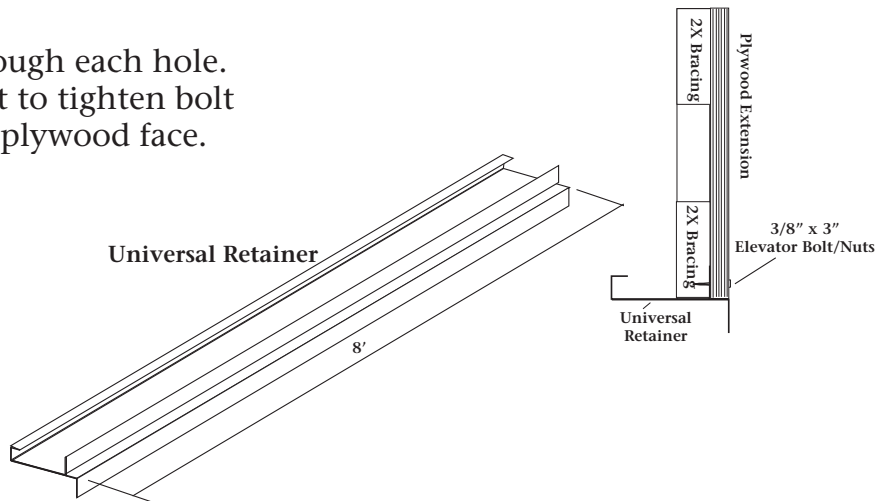

Glue Extension Vinyl to Plywood extension and the Universal Retainer leg

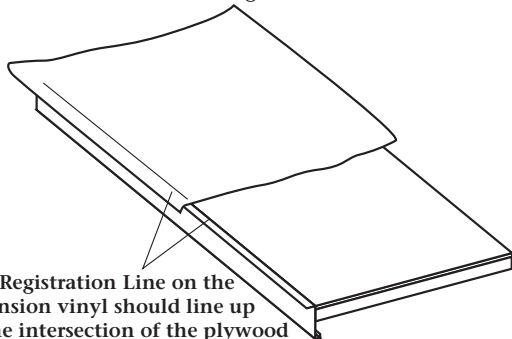

The Registration Line on the extension vinyl should line up at the intersection of the plywood and the Universal Retainer.

Glue the extension vinyl to the extension assembly and the Universal Retainer leg using Bill Tite 450. Make sure that the registration line on the vinyl aligns with the top of the Retainer leg and the bottom of the plywood face. Roll or smooth out the vinyl and let dry.

When the glue has dried, trim the excess edges of the vinyl with a sharp knife or blade.

# HF Clip-It Cut-Out System

The Formetco HF Hang-It Cut-Out System makes it easy to install extensions to the Hurricane Frame. The extension can be moved from one location to another even when the stringer spacing is different.

Two Cut-Out Masts are required for each 8' of extension. The Cut-Out Masts are 11' in height and punched with holes every 2" to easily adjust to different stringer spacings. Cut-Out Masts can support extensions that range from 11" to 5' above the top of the frame.

The Cut-Out Mast can be installed two ways on the Hurricane Frames. Using the HF Double Sided Hangers installed between the stringers and the HF Frame or with the Clip-It Cut-Out Angels Clips and "Z" Clips to the back of the stringers.

## Installation of HF Double Sided Hanger Brackets

1. Determine the measurement from the top of the extension to the top stringer. Install a HF Double Sided Hanger using HF 1/2" x 1 1/2" Carriage Bolts and Flange Nuts. Measure down to the 2nd stringer and install the second hanger bracket.

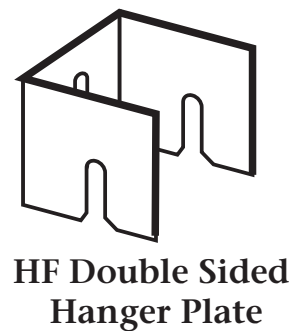
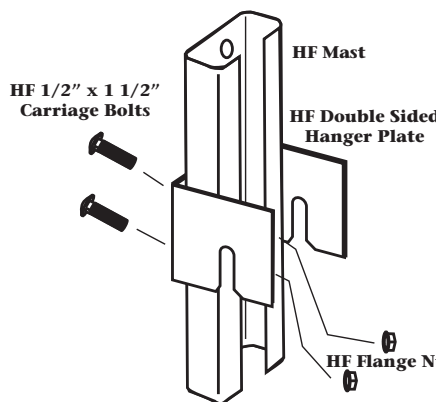
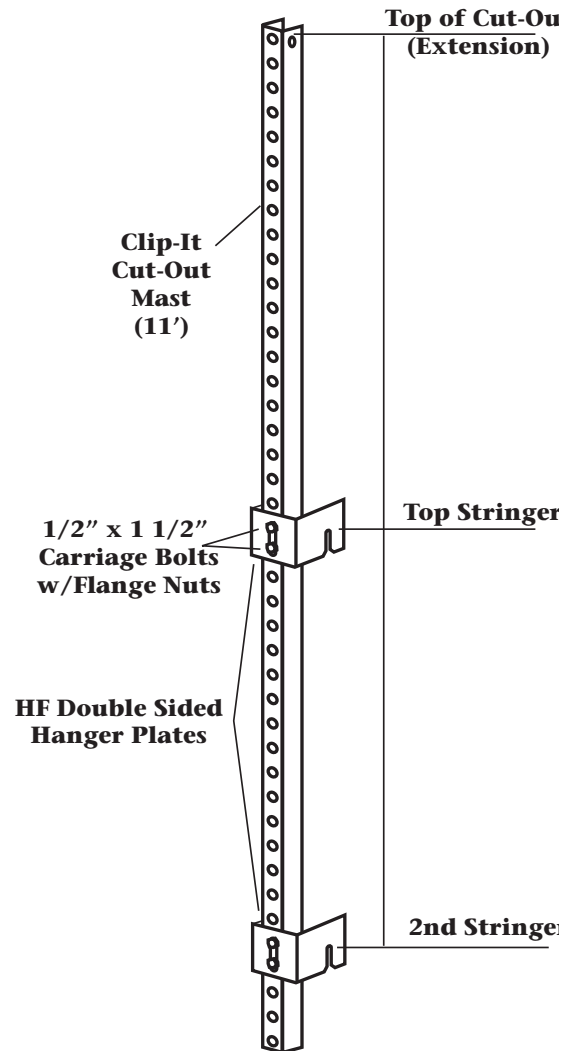

# HF Clip-It Cut-Out System

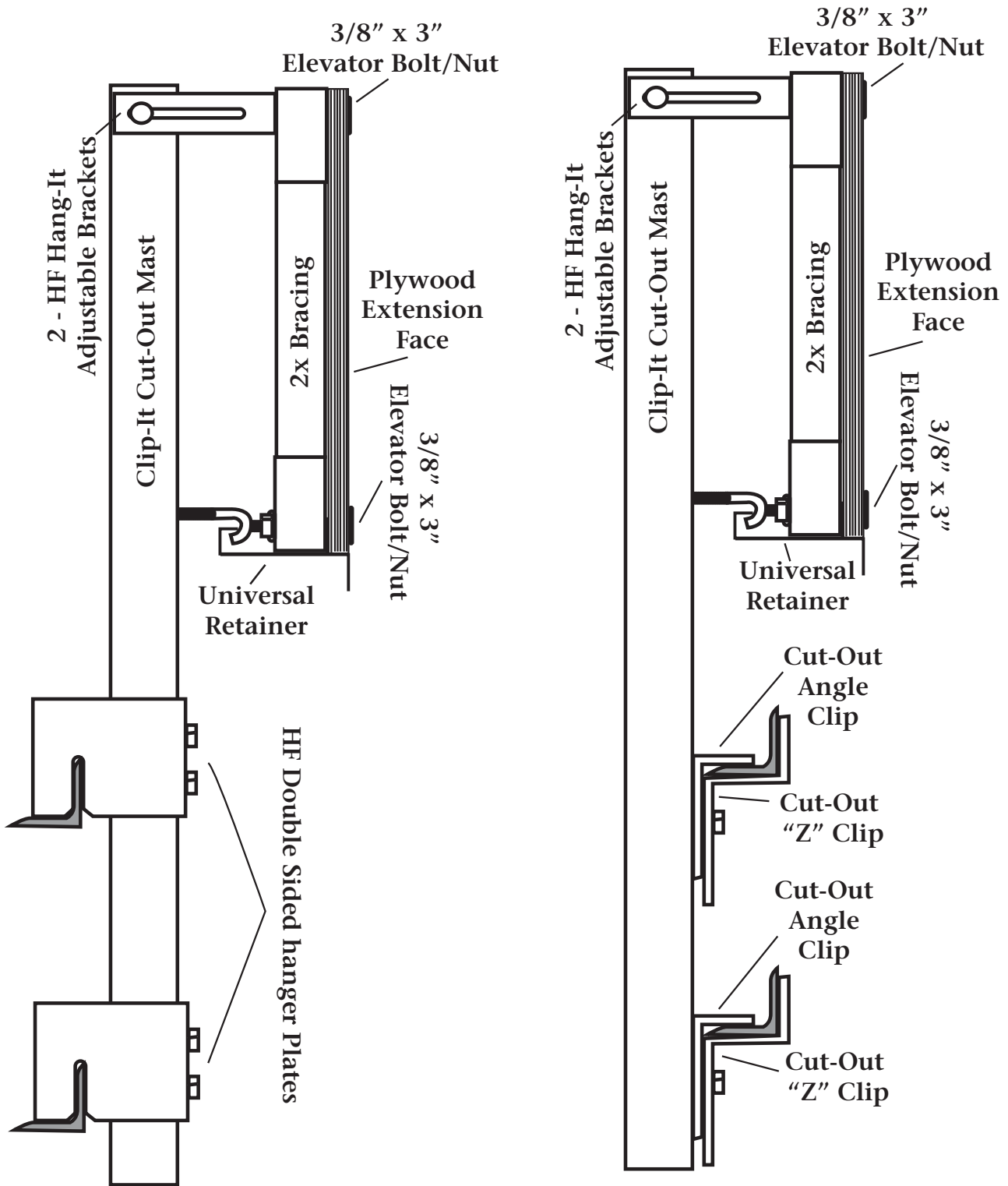

Cut-Out and Mast for Hurricane Frames

Cut-Out and mast for Rotarylok or Dura-Paint Sections

# HF Clip-It Cut-Out System

Install the Extension and Cut-Out Masts to structure angle iron stringers and top of face sections. The match lines on the face vinyl and the extension should be aligned.

Position the HF Adjustable Cut-Out Brackets to make sure the extension face is flat with the vinyl face.

Install the hook bolts from the Universal Retainer to each of the Cut-Out Masts. Tighten to pull the extension tight with the face.

The extension is now secured to the Masts at the top and bottom of the extension. The Cut-Out Masts are secured to the top two stringers, making the extension a part of the structure.

